

Year 10 Physics 2: Electricity Knowledge Organiser

2. Electrical charge and current

$$Q = I \times t$$

Q = Charge (in coulombs C)
 I = Current (in amps A)
 t = Time (in seconds s)

3. Resistance

$$V = I \times R$$

V = Potential difference/voltage (in volts V)
 I = Current (in amps A)
 R = Resistance (in ohms Ω)

Symbols and their units

Symbol	Meaning	Unit	Meaning
V	Potential difference	V	Volts
I	Current	A	Amps
R	Resistance	Ω	Ohms
Q	Charge	C	Coulombs
P	Power	W	Watts
E	Energy	J	Joules

1. Standard Circuit Diagram Symbols

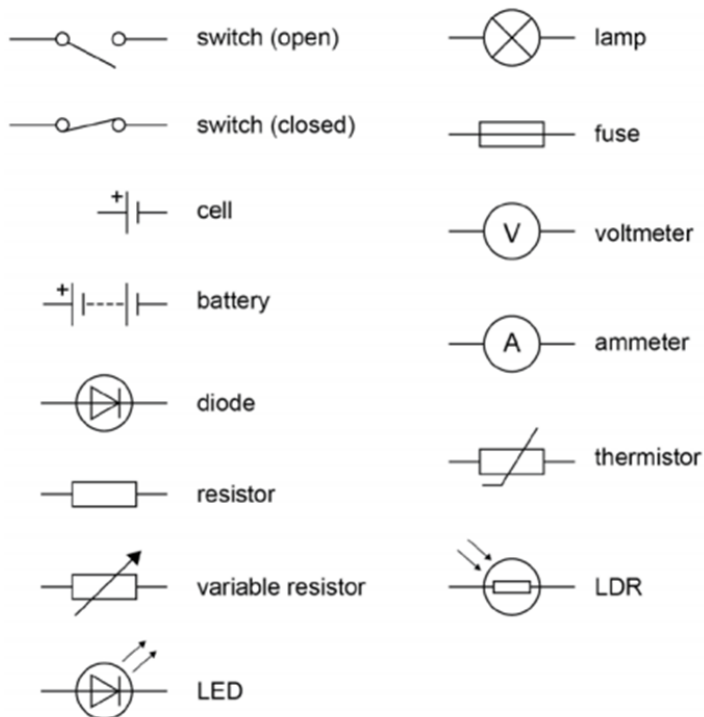

1	Switch (open)	8	LED (light emitting diode)
2	Switch (closed)	9	Lamp (bulb)
3	Cell	10	Fuse
4	Battery	11	Voltmeter
5	Diode	12	Ammeter
6	Resistor	13	Thermistor
7	Variable resistor	14	LDR (light-dependent resistor)

4. IV Characteristics and required Practical

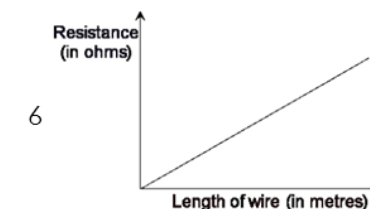
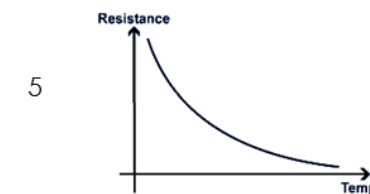
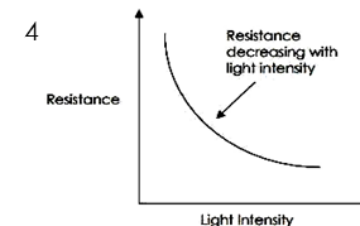
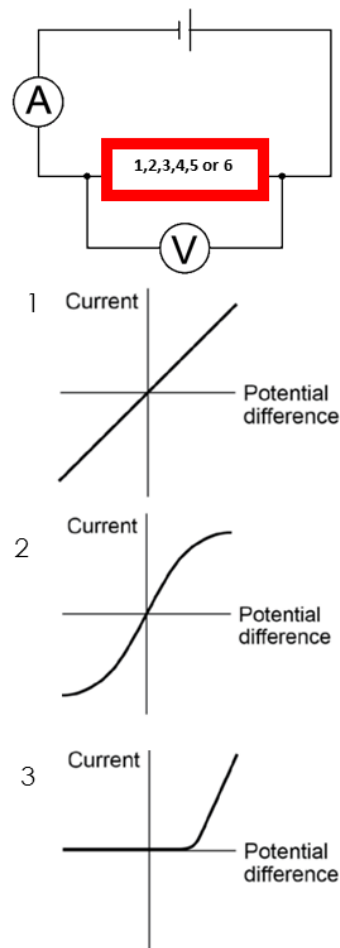

1	Ohmic resistor
2	Filament bulb
3	Diode
4	LDR
5	Thermistor
6	Resistance in a wire

Year 10 Physics 2: Electricity Knowledge Organiser

7. Electrical power

power = current² x resistance

$$P=I^2 R$$

power = current x potential difference

$$P=IV$$

energy transferred = charge flow x potential difference

$$E=QV$$

6. Mains electricity keywords

1. Earth wire	Prevents danger from short circuits
2. Fuse	Melts if current gets too high
3. Neutral wire	Carries the current away from plug
4. Live wire (230v)	Carries current to plug
5. Cable grip	Prevents a loose wire if cable is pulled
6. Double insulated cable	Prevents electric shock
7. Alternating current (AC)	Current which changes direction 50 times a second (50 Hz). Found in the mains.
8. Direct current (DC)	Current that only travel in one direction. Found in batteries.

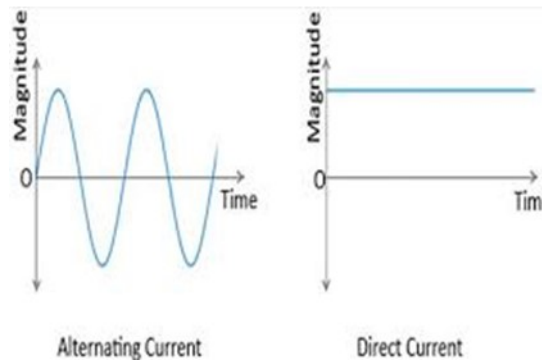
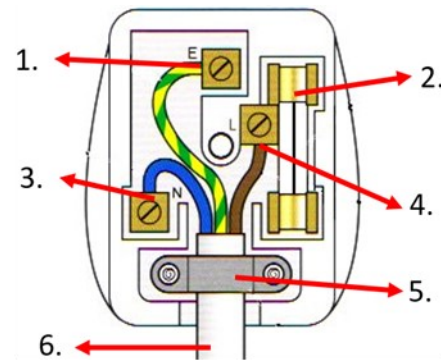

8. The National Grid

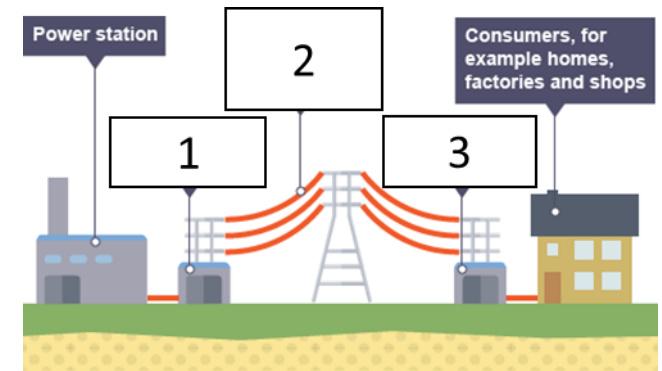

1. Step up transformer	Increase the voltage of the AC
2. High voltage transmission cables	High voltage reduces energy loss
3. Step down transformer	Decreases the voltage of the AC